

## RENDERING & PLASTERING MORTARS



### Table of Contents

Section	Title	Page
	Introduction	3
<b>1</b>	<b>Design, Essential Principles and Building Program</b>	<b>4</b>
1.1	Design Considerations	4
1.1.1	Durability relating to conditions of exposure	5
1.1.2	Protection afforded by architectural features and functions	6
1.1.2.1	Parapet and screen walls	6
1.1.2.2	Sills	7
1.1.2.3	Rendering at the base of walls above ground	8
1.1.3	Characteristics of the background	9
1.1.3.1	Strength of the background	9
1.1.3.2	Suction of the background	10
1.1.3.3	Key of the background	10
1.1.3.4	Movement joints in the background	11
1.1.3.5	Bedding joint reinforcement	13
1.1.3.6	Cracks in the background	13
1.1.3.7	Dimensional stability of the background	13
<b>2</b>	<b>Work on site, preparation and application</b>	<b>14</b>
2.1	Ancillary items and materials required	14
2.2	Site survey and preliminary work	15
2.2.1	Preparation of the background	15
2.2.1.2	Preparatory treatments	16
2.2.1.3	Rendering dissimilar backgrounds	17
2.2.1.4	Rendering concrete surfaces	18
2.2.1.5	Rendering parapets and screen walls	18
2.2.1.6	Rendering at base of walls	18
2.2.1.7	Rendering and associated expansion joints	18
2.2.1.8	Rendering across typical stress points	19
2.3	Mixing and application of various coats	20
2.3.1	Mixing requirements	20
2.3.2	Application of various coats	21
2.3.2.1	Weather Constraints	22
2.3.2.2	Application of KPRO Façade GP Render	23
2.3.2.3	Application of KPRO Façade DuraRend	24
2.3.2.4	Application of KPRO Façade UNO	25
2.3.2.5	Application of KPRO Façade Dash	26
2.3.2.6	Application of KPRO Façade HLR	27

#### Get in touch



**ROI** T: +353 (0)1 802 6300 E: technicaladmin@kilsaran.ie kilsaran.ie

**UK** T: +44 (0)161 872 8899 E: info@kilsaraninternational.co.uk kilsaraninternational.co.uk



## Introduction

KPro Façade rendering and plastering mortars are manufactured under a certified ISO 9001, 14001 and 50001 Management Systems. All products are produced, sampled, tested and CE marked as part of our EN998-1 Factory Production Control system. In addition to these controls a select number of products from the KPRO Façade range also hold NSAI Agreement certification.

The information held within this document is based on Kilsaran's experience of the products design, application, specification along with current regulations set out in national and European standards and codes of practice.

### Get in touch



**ROI** T: +353 (0)1 802 6300 E: [technicaladmin@kilsaran.ie](mailto:technicaladmin@kilsaran.ie) [kilsaran.ie](http://kilsaran.ie)

**UK** T: +44 (0)161 872 8899 E: [info@kilsaraninternational.co.uk](mailto:info@kilsaraninternational.co.uk) [kilsaraninternational.co.uk](http://kilsaraninternational.co.uk)

## 1. Design, Essential Principles and Building Program

Prior to commencement of all rendering/plastering work, and at the design stage, the project design should include working drawings and specifications prepared in sufficient detail to afford proper guidance for the execution of the work. Rendering and plastering designs should consider the following;

- a) The nature and condition of the background
- b) The nature and conditions of exposure of the rendering
- c) The finish/appearance required
- d) The type of rendering system
- e) Functional requirements of the rendering system
- f) Scaffolding requirements
- g) Any curing of materials or coats that might be required

In preparing a building programme and time schedule for the project the designer and building contractor should also consider;

- h) The suitability of the weather conditions for the application of the render
- i) The allocation of sufficient time for the background to be inspected and dry out prior to application of render coats.

### 1.1 Design Considerations

The structure should be designed and constructed so that the background remains as dry as practicable during construction. The purpose of the completed render is to restrict rain penetration into the background.

KPro Façade rendering mortars will enhance the aesthetics and weather resistance of concrete and masonry walls providing a decorative finish (KPRO UNO) or a durable surface for decorating coatings such as paint or organic renders. They are suitable for external or internal application to properly designed and constructed walls.

At the design stage there are a number of key aspects that should be considered by the designer to match a rendering system with their project design. These include,

- Durability relating to conditions of exposure
- Protection afforded by architectural features and functions
- Characteristics of the background

#### Get in touch



**ROI** T: +353 (0)1 802 6300 E: technicaladmin@kilsaran.ie kilsaran.ie

**UK** T: +44 (0)161 872 8899 E: info@kilsaraninternational.co.uk kilsaraninternational.co.uk

### 1.1.1 Durability relating to conditions of exposure

KPro Façade rendering mortars, when applied to properly designed buildings and applied in accordance with this document, I.S. EN13914-1, B.S. EN 13914-1, SR325 and PD6697 will have adequate resistance to wind and wind-driven rain in all exposures in Ireland and the UK. The maps below are taken from SR 325 and B.S. EN 13914-1 respectively. They illustrate the wind-driven rain index and exposure categories for a given region or area. These have been combined in the accompanying table below.



Ireland - I.S. EN 13914-1/SR 325

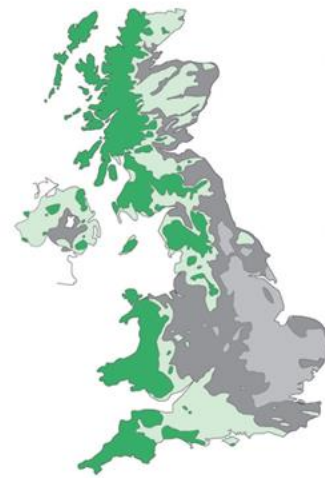

UK - B.S. EN 13914-1/PD6697

Table 1		
Classification of Exposure to Wind-driven Rain	Ireland	UK
	SR 325	B.S. EN 13914-1/PD 6697
Sheltered	19 – 37 L/m <sup>2</sup> per spell	< 33 L/m <sup>2</sup> per spell
Moderate	29 – 58 L/m <sup>2</sup> per spell	33 to < 56.5 L/m <sup>2</sup> per spell
Severe	68 – 123 L/m <sup>2</sup> per spell	56.5 – < 100 L/m <sup>2</sup> per spell
Very Severe	> 98 L/m <sup>2</sup> per spell	> 100 L/m <sup>2</sup> per spell

\* Please note that SR 325 states that severe category obtains in districts where the driving rain index is 7 or more.

#### Get in touch



**ROI** T: +353 (0)1 802 6300 E: technicaladmin@kilsaran.ie kilsaran.ie

**UK** T: +44 (0)161 872 8899 E: info@kilsaraninternational.co.uk kilsaraninternational.co.uk

Both I.S. EN 13914-1:2016 and B.S. EN 13914-1 state in section 6.7 – *Resistance to rain penetration* that for factory made renders being used in severe conditions of exposure, where the rendering is subject to much rain, renders which conform to the requirements of EN 998-1 and having a capillary water absorption Class  $W_c 2$  should be used. KPRO Façade renders are independently tested for capillary water adsorption and have been confirmed to be  $W_c 2$ , thus satisfying this requirement. For rendering in severe conditions of exposure (as detailed in Table 1) it is recommended to increase the finished coat thickness to 20mm for single coat renders. For further details on individual product performance data please refer to the product DOP (Declaration of Performance).

### 1.1.2 Protection afforded by architectural features and functions

The detailing of architectural features can affect the appearance and durability of rendering and careful consideration should be given to their design, in particular to diverting run-off moisture away from the face of the render. Wherever possible, advantages should be taken of architectural features that protect the rendering. Such protective features become more important in more severe exposure conditions.

#### 1.1.2.1 Parapet and screen walls

Parapet and screen walls should be carefully designed to avoid problems associated with rain penetration. In particular renders should not be used as a finish on horizontal or sloping surfaces exposed to weather.

Walls should be protected by a coping with a damp proof membrane immediately beneath it. The coping should be throated and project beyond the face of the render by a minimum of 40mm (from the throat). Please see figure 1 below

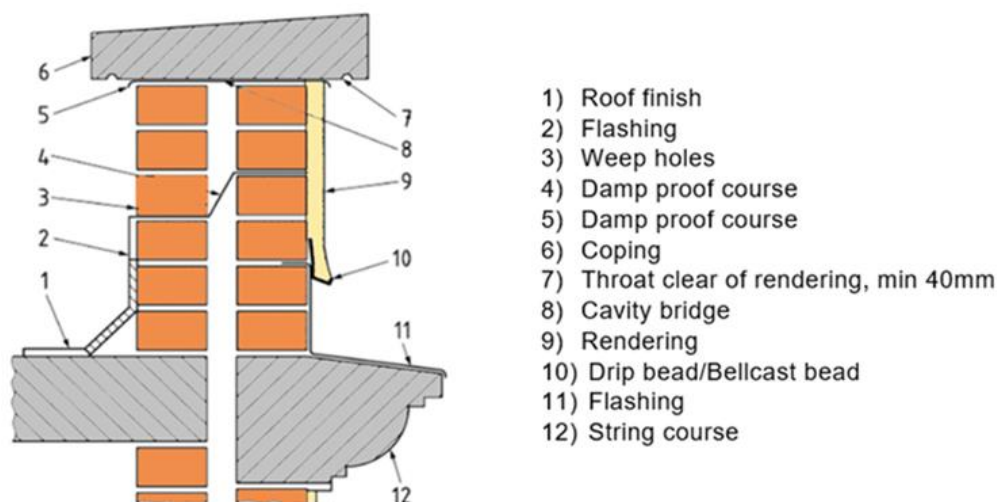

Figure 1.

#### Get in touch



ROI T: +353 (0)1 802 6300 E: technicaladmin@kilsaran.ie kilsaran.ie

UK T: +44 (0)161 872 8899 E: info@kilsaraninternational.co.uk kilsaraninternational.co.uk

### 1.1.2.2 Sills

Sills should be of a material of low water permeability, project beyond the face of the rendering and extend beyond the line of the reveal. Sills shall have an efficient throat or dip on their underside which should be no less than 40mm away from the face of the wall and also be designed to prevent water running onto the wall below or into jams.

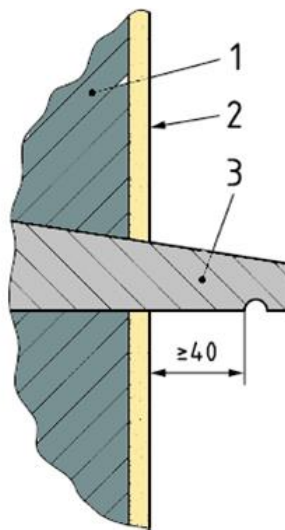

- Key**
- 1 wall
  - 2 render
  - 3 sill

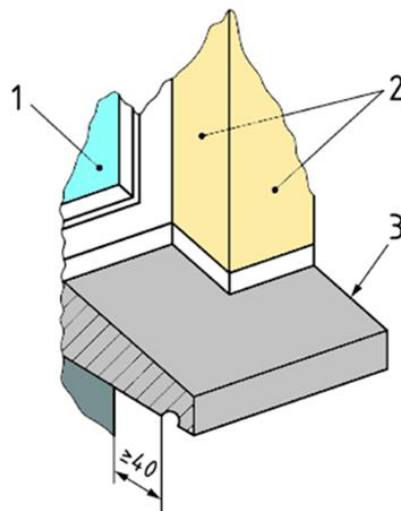

- Key**
- 1 window
  - 2 rendered wall
  - 3 sill

**Figure 2 - Sill detail for concrete or stone sills**

#### Get in touch



**ROI** T: +353 (0)1 802 6300 E: technicaladmin@kilsaran.ie kilsaran.ie  
**UK** T: +44 (0)161 872 8899 E: info@kilsaraninternational.co.uk kilsaraninternational.co.uk



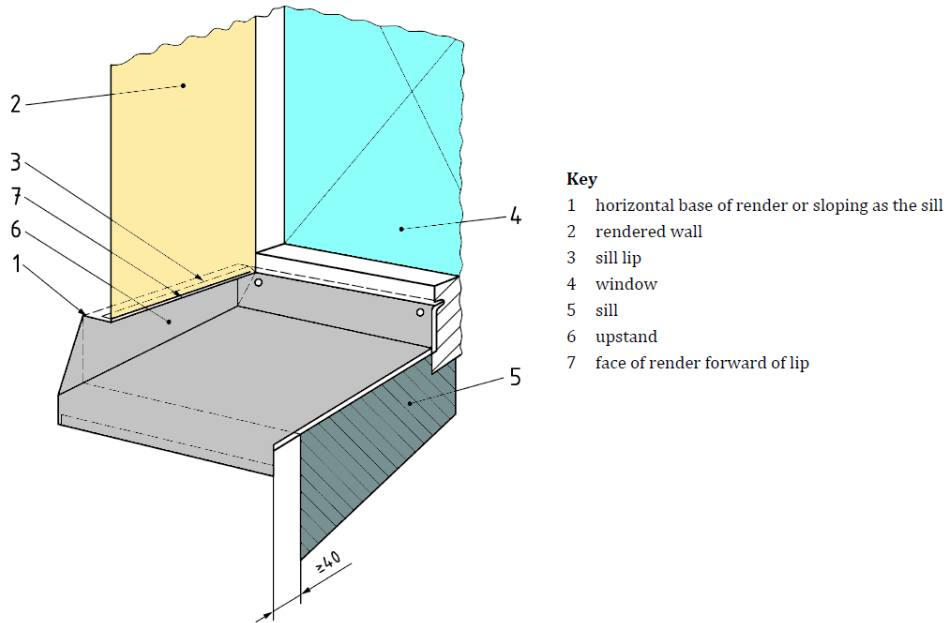

**Figure 3 - Sill detail for metal sills**

### 1.1.2.3 Rendering at the base of walls above ground

Render can only be applied between damp proof course and ground level, or across the damp proof course, when special precautions are taken. A PVC or stainless steel bellcast or stop bead should be placed a minimum of 150mm above ground level or above the damp proof course level if it at a higher level (figure 4).

Depending on the strength of the background material, a suitable render shall be used. For example, on a concrete background a render class of CS III or CS IV, and with a capillary water absorption of Wc2 should be used. For background materials with a compressive strength  $\leq 6\text{N/mm}^2$  a render class of CS II or CS III and with a capillary water absorption of Wc2 should be used.

#### Get in touch



**ROI** T: +353 (0)1 802 6300 E: technicaladmin@kilsaran.ie kilsaran.ie

**UK** T: +44 (0)161 872 8899 E: info@kilsaraninternational.co.uk kilsaraninternational.co.uk

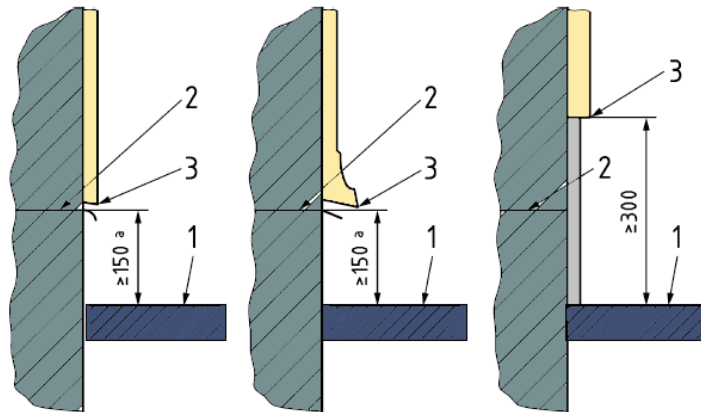

**Key**

- 1 ground level
- 2 damp-proof course
- 3 socle or drip bead

<sup>a</sup> A higher minimum distance may be necessary due to local climatic conditions.

**Figure 4 - Rendering at base of walls**

### 1.1.3 Characteristics of the background

The background characteristics, as described in this section, should be considered when choosing a rendering system. KPRO Façade rendering mortars are designed for application to most common brick and block masonry backgrounds. The background and its constituent materials should conform to their relevant standards. The following characteristics should be considered at the design stage,

#### 1.1.3.1 Strength of the background

The background should be able to adequately support and restrain the rendering system. Weak, friable backgrounds may not provide adequate support and thus an adequate support may be required e.g. metal lath etc.

#### Get in touch



**ROI** T: +353 (0)1 802 6300 E: technicaladmin@kilsaran.ie kilsaran.ie

**UK** T: +44 (0)161 872 8899 E: info@kilsaraninternational.co.uk kilsaraninternational.co.uk

### 1.1.3.2 Suction of the background

KPRO Façade rendering mortars rely on a combination of suction and surface texture to achieve a sufficient bond. The substrate should be checked for suction by spraying the surface with water. If the water is not absorbed (low suction) or absorption is excessively fast, achieving an adequate bond may not be possible. In such instances a preparatory treatment like KPRO Super Bond may be required and advice from the manufacturer should be sought.

However, if the water is readily absorbed (high suction) by the substrate then it may be too absorbent and pre-wetting of the substrate will be necessary. In most instances the wetting of the substrate can be controlled by spraying, but not soaking, the background with water in the hours before render application.

### 1.1.3.3 Key of the background

KPRO Façade rendering mortars can be spray applied to most common block and brick surfaces without the need of a scud coat. If applying the render by hand the use of a suitable scud coat is required. A 2:1 sand and cement coat or an adhesive spatter dash (Kilsaran Super Bond Render) should be applied to the background by throwing it from a short distance, ensuring complete and even coverage of the substrate.

For smooth dense substrates that do not provide a natural key, the key must be provided artificially by the following,

- a) Application of a stipple coat/scratch coat using KPRO Façade Super Bond.
- b) The use of a suitable metal lathing to act as a carrier.

The designer should also consult I.S. EN 13914-1 or B.S. EN 13914-1, sections 6.4 [*Adequacy of the background*] and section 7.5 [*Preparation of the background*] relating to this matter.

#### Get in touch



**ROI** T: +353 (0)1 802 6300 E: [technicaladmin@kilsaran.ie](mailto:technicaladmin@kilsaran.ie) [kilsaran.ie](http://kilsaran.ie)  
**UK** T: +44 (0)161 872 8899 E: [info@kilsaraninternational.co.uk](mailto:info@kilsaraninternational.co.uk) [kilsaraninternational.co.uk](http://kilsaraninternational.co.uk)

**Kilsaran**  
ideas taking shape

### 1.1.3.4 Movement joints in the background

The project design should specify the type and location of movement joints in the structure. This should be done in consultation with the following standards,

- I.S. EN 1996-2: Eurocode 6 – *Design of Masonry Structures - Design considerations, selection of materials and execution of masonry*
- B.S. EN 1996-2 – *Design of Masonry Structures - Design considerations, selection of materials and execution of masonry*
- SR 325: *Recommendations for the design of masonry structures in Ireland to Eurocode 6*
- PD6697: *Recommendations for the design of masonry structures to BS EN 1996-1-1 and BS EN 1996-2*
- BS 6093: *Design of joints and jointing in building construction*

A summary of points taken from all the above mentioned documents is as follows,

- Vertical movement joints in masonry should be located no further than 6 metres apart (Figure 5)
- The distance from the first vertical joint, from a restrained vertical edge of a wall, should not exceed half that of the 6 metres i.e. should be 3 metres from the corner. (Figure 6)
- The ratio of length to height of the panels should generally not exceed 3:1.
- Joints in the masonry background should follow through the rendered surface.

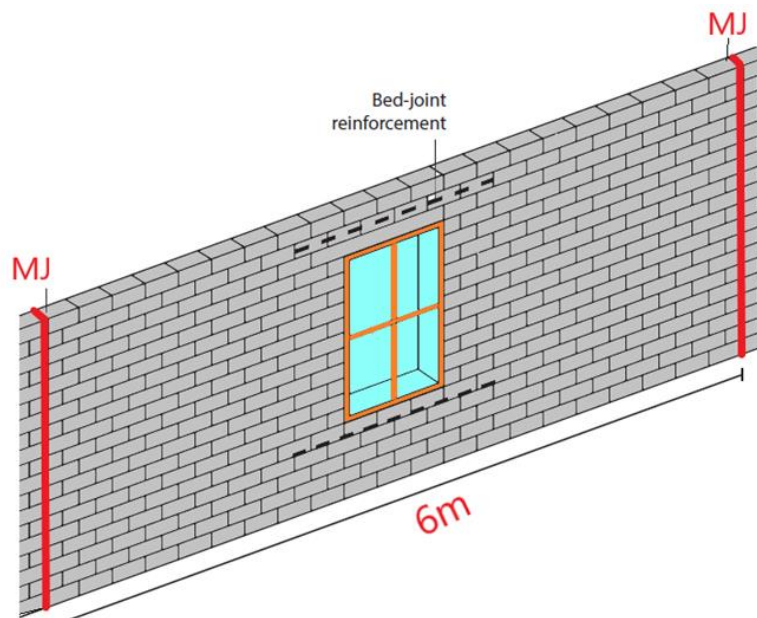

**Figure 5 - Distance between vertical movement joints**

#### Get in touch



ROI T: +353 (0)1 802 6300 E: technicaladmin@kilsaran.ie kilsaran.ie

UK T: +44 (0)161 872 8899 E: info@kilsaraninternational.co.uk kilsaraninternational.co.uk

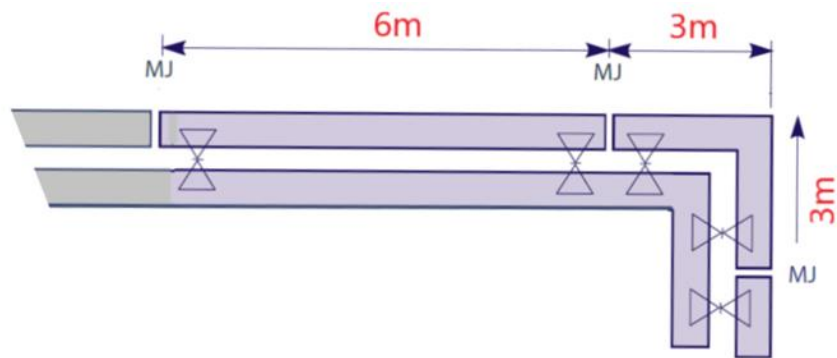

**Figure 6 - Location of joint from a restrained edge**

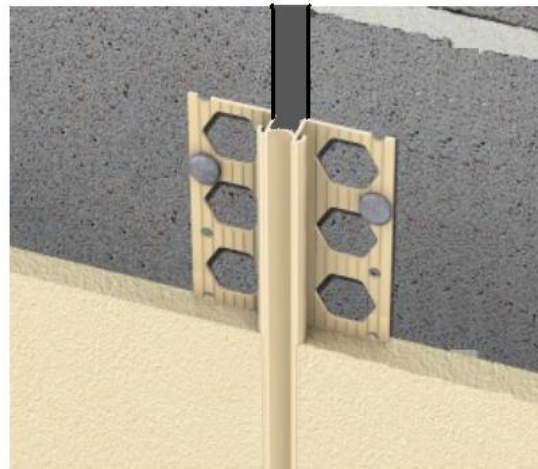

**Figure 7 - Joints in render follow joints in background**

**Get in touch**



**ROI** T: +353 (0)1 802 6300 E: technicaladmin@kilsaran.ie kilsaran.ie  
**UK** T: +44 (0)161 872 8899 E: info@kilsaraninternational.co.uk kilsaraninternational.co.uk

### 1.1.3.5 Bedding joint reinforcement

It is well documented that the cracking of the substrate can be significantly reduced if bed joint reinforcement is used, at weak points or typical stress points in the structure e.g. above and below window and door openings. Kilsaran therefore recommend its use in these areas in all instances.

### 1.1.3.6 Cracks in the background

Prior to rendering over cracked backgrounds, a structural survey should be carried out to determine the cause of the crack and if further movement is likely to take place.

Precautions should be taken when rendering backgrounds with existing cracks. Such precautions may include the use of fibreglass mesh reinforcement or the use of a carrier such as metal lath. It is important to note that cracked backgrounds cannot be rendered without risk.

### 1.1.3.7 Dimensional stability of the background

Dimensional changes of the background should have largely taken place prior to rendering. Render applied to backgrounds which may move are likely to crack e.g. with movement of the structure, deflection of floor slabs, shrinkage of concrete and/or high moisture content of the masonry.

KPRO Facade Renders should only be applied to stable and mature backgrounds. **A minimum of one month** should be allowed following completion of the wall construction before application of the render commences. All substrates must be clean, sound, and free from dust, grease and debris. Fill any voids and recesses with KPRO Facade GP Render and to level uneven surfaces and minimise variations in the finished product.

#### Get in touch



ROI T: +353 (0)1 802 6300 E: technicaladmin@kilsaran.ie kilsaran.ie

UK T: +44 (0)161 872 8899 E: info@kilsaraninternational.co.uk kilsaraninternational.co.uk

## 2. Work on site, preparation and application

The application of KPRO Façade rendering mortars must be carried out in accordance with this document, the manufacturer's instructions and the recommendations set out in I.S. EN 13914-1, B. S. EN 13914-1, I.S. EN 1996 (Eurocode 6), B.S. EN 1996 (Eurocode 6), SR 325 and PD 6697. It is essential that the application of KPRO Façade rendering mortars is carried out by experienced rendering contractors

### 2.1 Ancillary items and materials required

The following list outlines items such as tools, mixers and materials required for the correct application of KPRO Façade rendering mortars.

Table 2		
Product	Material	Related Standard
Tools and equipment	<ul style="list-style-type: none"> <li>Plasterers knife</li> <li>Plasterers float and sponge</li> <li>Darby/straight and serrated edge</li> <li>Spatula</li> <li>Window protective film</li> <li>Thickness gauge</li> <li>Ashlar cutter</li> <li>Soft bristled brush</li> <li>Measuring bucket (hand application)</li> <li>Approved spray render machine</li> <li>I - bar/ I - section</li> </ul>	n/a
Reinforcement	<ul style="list-style-type: none"> <li>Glass fibre mesh cloth</li> </ul>	<ul style="list-style-type: none"> <li>EN 13946</li> </ul>
	<ul style="list-style-type: none"> <li>Expanded metal (stainless steel or zinc coated steel)</li> <li>Plain or profiled welded wire mesh (stainless steel or zinc coated steel)</li> </ul>	<ul style="list-style-type: none"> <li>EN 13658-2</li> <li>Stainless steel to EN 10088-1</li> <li>Zinc coated steel to EN ISO 16120-2 and EN 10346</li> </ul>
Bead profiles	<ul style="list-style-type: none"> <li>Stainless steel and zinc coated steel</li> </ul>	<ul style="list-style-type: none"> <li>EN 13658-2</li> <li>Stainless steel to EN 10088-1</li> <li>Zinc coated steel to EN ISO 16120-2 and EN 10346</li> </ul>
	<ul style="list-style-type: none"> <li>Plastic and plastic coated beads</li> </ul>	n/a

#### Get in touch



ROI T: +353 (0)1 802 6300 E: technicaladmin@kilsaran.ie kilsaran.ie

UK T: +44 (0)161 872 8899 E: info@kilsaraninternational.co.uk kilsaraninternational.co.uk

## 2.2 Site survey and preliminary work

KPRO Façade rendering mortars are satisfactory for use on brickwork, block work and suitably prepared concrete backgrounds. It is essential that such walls are designed and constructed to prevent moisture penetration and the formation of condensation. KPRO Façade rendering mortars are not suitable for application to gypsum plaster. However, KPRO Façade GP Render and DuraRend are suitable substrate for internal gypsum skim coats.

Older buildings in coastal areas should be checked for salt content of the substrate. Test results will determine the suitability of the substrate to receive a render and will highlight any need for substrate treatments. KPRO Façade rendering mortars should not be applied to an area where there is evidence of corrosion of steel reinforcement in the masonry. KPRO Façade rendering mortars should be protected at the top of walls by an adequate overhang or by adequately sealed, purpose made flashing.

A pre-application survey of the property should be carried out by the designer and/or rendering contractor to determine the suitability of the substrate to receive the render, and to note whether any repairs to the structure are necessary prior to application. The survey should consider, but may not be limited to;

- Preliminary treatment of the background
- Positioning of beads
- Detailing around doors windows and openings
- Damp-proof course level
- Exact position of movement joints
- Areas where flexible sealants must be used
- Any alterations in external plumbing or ducting

### 2.2.1 Preparation of the background

KPRO Façade rendering mortars should only be applied to stable and mature backgrounds. A minimum of one month should be allowed following completion of the wall construction before application of the render commences. All substrates must be clean, sound, and free from dust, grease, debris, and organic growth. Substrates presenting with organic/biological growth must be treated and cleaned prior to rendering. Fill any voids and recesses with KPRO Façade GP Render and to level uneven surfaces and minimise variations in the finished product. Do not apply Kilsaran One Coat Renders to frozen, thawing or excessively wet substrates.

All block work and brick work should be designed and constructed in accordance with current standards and regulations and in particular I.S. EN 1996 (Eurocode 6), B.S.EN 1996 Eurocode 6), SR325 and PD 6697.

#### Get in touch



**ROI** T: +353 (0)1 802 6300 E: technicaladmin@kilsaran.ie kilsaran.ie

**UK** T: +44 (0)161 872 8899 E: info@kilsaraninternational.co.uk kilsaraninternational.co.uk

**Kilsaran**  
ideas taking shape



### 2.2.1.2 Preparatory treatments

KPRO Façade rendering mortars rely on a combination of suction and surface texture to achieve sufficient bond. The type and level of pre-treatment of the background is dependent on its strength and suction behaviour.

The substrate should be checked for suction by spraying the surface with water. Ideally the substrate should slowly draw the water into the surface leaving a wet residue. If the water is not absorbed, or the absorption is excessively slow, obtaining a sufficient bond may not be possible. In such instances a preparatory treatment such as KPRO Façade Super Bond may be required, and advice should be sought from Kilsaran (Figure 8). However, if the water is readily absorbed by the substrate then it may be too absorbent and pre-wetting of the substrate will be necessary to prevent render mixing water being readily extracted by the background. In most instances the excessive suction of a substrate can be controlled by spraying, but not soaking, the substrate with water in the hours prior to render application.



**Figure 8 - Checking background suction and application of Super Bond**

Please note, when KPRO Façade rendering and plastering mortars are being applied by hand the use of a suitable scud coat pre-treatment is required to provide a suitable key. This is not required when applying the products by spray render machine.

#### Get in touch



**ROI** T: +353 (0)1 802 6300 E: [technicaladmin@kilsaran.ie](mailto:technicaladmin@kilsaran.ie) [kilsaran.ie](http://kilsaran.ie)

**UK** T: +44 (0)161 872 8899 E: [info@kilsaraninternational.co.uk](mailto:info@kilsaraninternational.co.uk) [kilsaraninternational.co.uk](http://kilsaraninternational.co.uk)

**Kilsaran**  
ideas taking shape

### 2.2.1.3 Rendering dissimilar backgrounds

Where the substrate to be rendered consists of different materials, or materials of variable suction, the possibility of differential movement at their junction should be considered. Any anticipated movement should be accommodated by forming a straight joint right through the rendering in line with the change of background. In cases where differential movement is less likely and it is not appropriate, the effect on the rendering from slight movement in the background can be minimised by,

- a) Embedment of an alkali resistant mesh cloth in the undercoat (in the first pass for KPRO Façade UNO and KPRO Façade DuraRend) with a **minimum 200mm overlap**. (Figure 9)
- b) Provision of a strip of metal lathing not less than 300mm wide with an isolating membrane behind, fixed across the junction and embedded in the undercoat. (Note this method is not suitable for single-coat renders)

the recommendations set out above and in I.S. EN 13914-1:2016/B.B. EN 13914-1 should be followed. Section 6.4 - *Adequacy of the background*, 7.5 – *Preparation of background* and 6.14.5.3 – *Dissimilar backgrounds that cause differential movement*, outline steps to be taken when rendering over backgrounds with variable suction (noted above). KPRO Façade Super Bond can be applied as a stipple coat to such substrates to equalise the suction from the background.

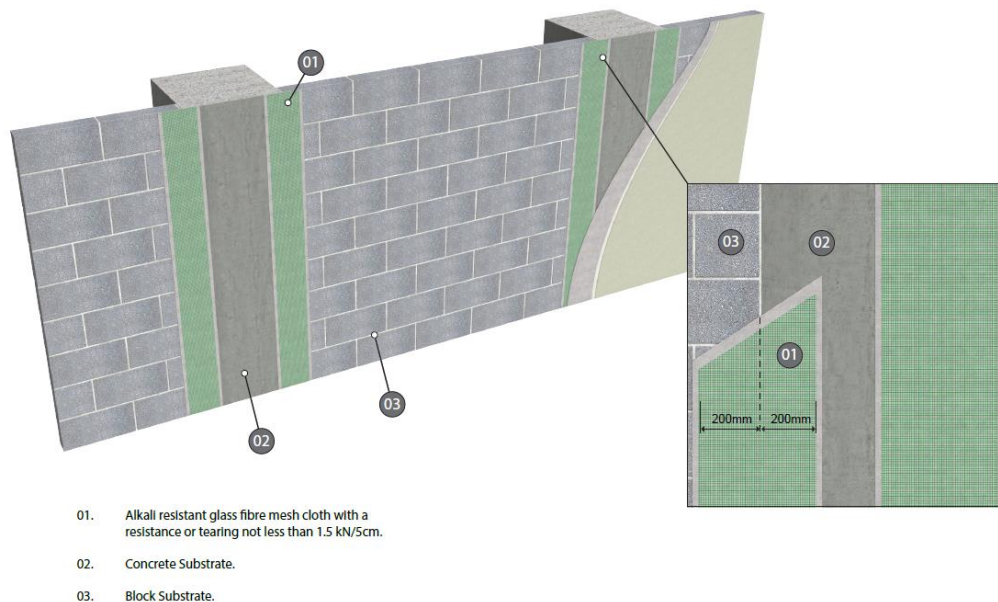

**Figure 9 - Meshing across dissimilar backgrounds**

#### Get in touch



**ROI** T: +353 (0)1 802 6300 E: technicaladmin@kilsaran.ie kilsaran.ie  
**UK** T: +44 (0)161 872 8899 E: info@kilsaraninternational.co.uk kilsaraninternational.co.uk

#### 2.2.1.4 Rendering concrete surfaces

When applying KPRO Façade rendering mortars to concrete backgrounds ensure all dirt, dust, loose matter, efflorescence, formwork oil and organic growth is removed by brushing and washing the surface with a suitable solution. In cases where KPRO Façade rendering mortars are to be applied at wall openings incorporating concrete lintels, refer to section 2.2.1.3 (Rendering dissimilar backgrounds) of this document. For projects involving the use of KPRO Façade rendering mortars on concrete substrates, a method statement must be prepared by the designer and rendering contractor. The method statement should address the choice of shutter, mould release agent, removal of laitance, and the application of a render key coat such as KPRO Façade Super Bond Render. In all cases the key coat material needs to be approved by Kilsaran. Application of KPRO Façade rendering mortars to concrete surfaces is limited to two stories above ground level. In all instance guidance should be sought from Kilsaran.

#### 2.2.1.5 Rendering parapets and screen walls

KPRO Façade rendering mortars should not be applied onto flat or sloping surfaces. An adequate flashing must always be provided to prevent water penetrating behind the render. Please refer to section [1.1.2.1 *Parapet and screen walls*].

#### 2.2.1.6 Rendering at base of walls

Render can only be applied between damp proof course and ground level, or across the damp proof course, when special precautions are taken. A PVC or stainless steel bellcast or stop bead should be placed 150mm above ground level or above the dpc level if it at a higher level. Please refer to section [1.1.2.3 *Rendering at the base of walls above ground*], for further details.

#### 2.2.1.7 Rendering and associated expansion joints

The project design should specify the type and location of movement joints in the structure. This should follow all current standards and codes of practice and allow for clear and concise instruction to the rendering/plastering contractor regarding the necessity and preparation of joints in the rendering/plastering. In summary joints are required every 6 linear metres and 3 metres for restrained edges. Please refer to section [1.1.3.4 *Movement joints in masonry*] for further information.

#### Get in touch



ROI T: +353 (0)1 802 6300 E: technicaladmin@kilsaran.ie kilsaran.ie

UK T: +44 (0)161 872 8899 E: info@kilsaraninternational.co.uk kilsaraninternational.co.uk

### 2.2.1.8 Rendering across typical stress points

The ability of rendering mortars to displace and counteract stresses afforded by the background can be improved by the inclusion of suitable reinforcement. An alkali resistant mesh cloth must be included in rendering at natural stress points e.g. above and below window and door openings, junction of dissimilar backgrounds (see section 2.2.1.3), and at natural crack inducing points such as at weep holes and vents.

In relation to areas above and below window and door opening, the mesh should be cut into appropriately sized strips and span the typical area of weakness by 500mm. The mesh should be fully embedded in the first pass of render (KPRO Façade Uno or KPRO Façade DuraRend) or in the undercoat overlapping around the opening. **Ensure that the mesh cloth does not make contact with the background.** Please see figure 10 for additional information. **KPRO Façade GP Render and DuraRend require a 10mm aperture mesh, whereas KPRO UNO, Dash Receiver and Super Bond can use a 4mm aperture mesh.**

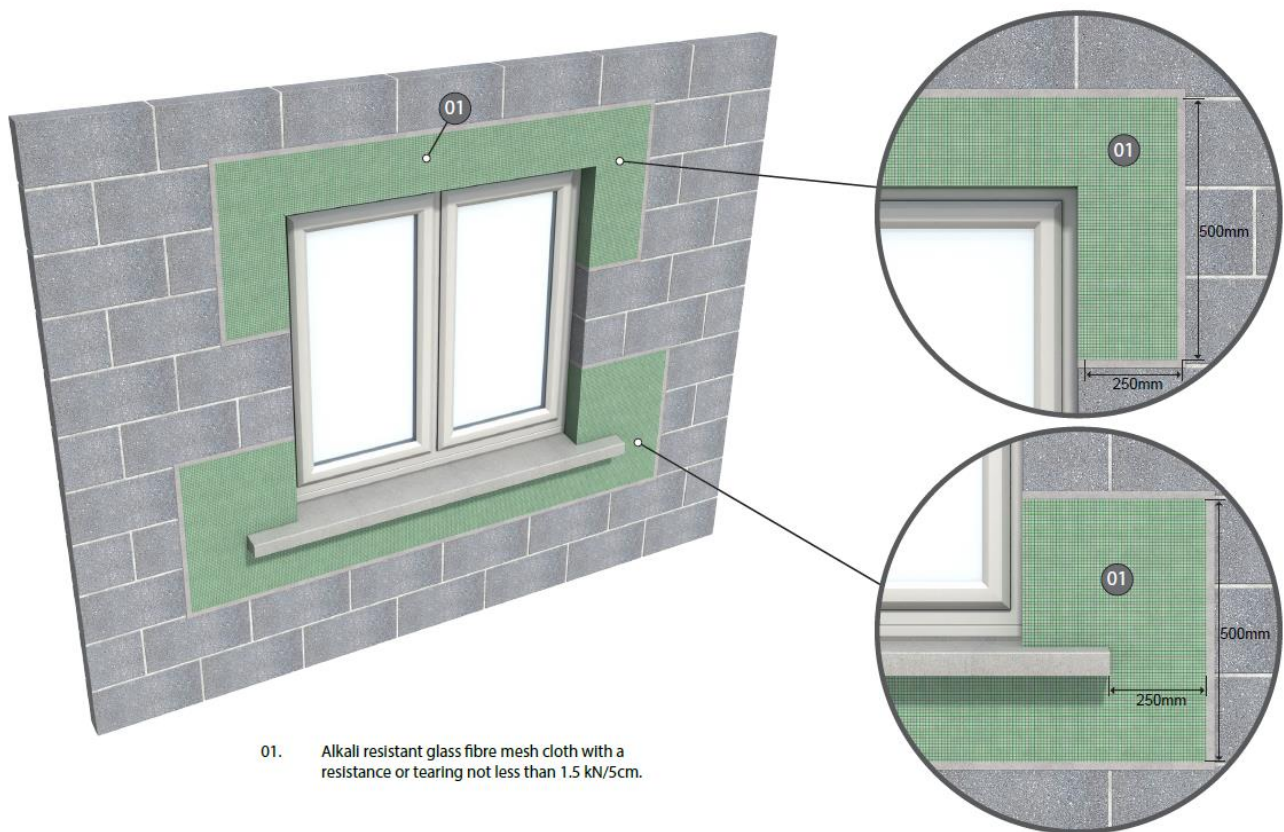

**Figure 10 - Mesh reinforcement around openings**

#### Get in touch



**ROI** T: +353 (0)1 802 6300 E: technicaladmin@kilsaran.ie kilsaran.ie  
**UK** T: +44 (0)161 872 8899 E: info@kilsaraninternational.co.uk kilsaraninternational.co.uk

## 2.3 Mixing and application of various coats

KPRO Façade rendering and plastering mortars are formulated pre-mixed dry mortars that only require the addition of clean potable water to produce a plastic mortar suitable for machine or hand application.

### 2.3.1 Mixing requirements

KPRO Façade rendering and plastering mortars require the addition of a pre-determined amount of water. Please see below table to see typical water addition quantities for each product. Please note mixing vessels vary in power and quality of mixing. The values below are for a guideline only.

Table 3	
Product	Typical water addition per 25 kg bag
KPRO Façade GP Render	4.5 – 5.0 litres
KPRO Façade DuraRend	4.75 – 5.0 litres
KPRO Façade UNO	5.0 – 6.0 litres
KPRO Façade Dash	5.0 – 6.0 litres
KPRO Façade Super Bond	5.0 – 5.25 litres
KPRO Façade HLR	5.0 – 6.0 litres

For spray application of KPRO Façade rendering and plastering mortars, many spray render machines vary in their mixing techniques and water requirements. The below table gives typical water settings for the most common machine types used in Ireland and the UK.

Table 4		
Machine	Typical water Setting	Typical pressure Setting
PFT G4	350-380 litres	3 bar
PFT G5	350-380 litres	3 bar
Lancy PH9B-R	30-35 litres (6 bag mix)	20-25 bar
Lancy PH9B-S	30-35 litres (6 bag mix)	20-25 bar
Putzmeister SP11 – LMR	30-35 litres (6 bag mix)	20-25 bar

*\*Note the data in this table is a guideline only. Consult machine manufacturer for further guidance.*

#### Get in touch



ROI T: +353 (0)1 802 6300 E: technicaladmin@kilsaran.ie kilsaran.ie

UK T: +44 (0)161 872 8899 E: info@kilsaraninternational.co.uk kilsaraninternational.co.uk

### 2.3.2 Application of various coats

The application of KPRO Façade rendering mortars must be carried out in accordance with this document, the manufacturer's instructions and the recommendations set out in I.S. EN 13914-1, B. S. EN 13914-1, I.S. EN 13914-2, B.S. EN 13914-2, I.S. EN 1996 (Eurocode 6), B.S. EN 1996 (Eurocode 6), SR 325 and PD 6697. **It is essential that the application of KPRO Façade rendering mortars is carried out by experienced rendering contractors**

As covered in section 2.2.1 (*Preparation of the background*) of this document KPRO Façade rendering mortars can be spray applied to most common block and brick surfaces without the need of a scud coat. If applying the render by hand the use of a suitable scud coat is required. A 2:1 sand and cement coat or an adhesive spatter dash (KPRO Super Bond Render) should be applied to the background by throwing it from a short distance, ensuring complete and even coverage of the substrate. 1 -2 hours after its application, dampen down the scud with a fine mist of water to ensure adequate hydration of the cement. Allow the scud coat to dry and harden fully before application of KPRO Façade rendering mortars.

#### Get in touch



**ROI** T: +353 (0)1 802 6300 E: [technicaladmin@kilsaran.ie](mailto:technicaladmin@kilsaran.ie) [kilsaran.ie](http://kilsaran.ie)

**UK** T: +44 (0)161 872 8899 E: [info@kilsaraninternational.co.uk](mailto:info@kilsaraninternational.co.uk) [kilsaraninternational.co.uk](http://kilsaraninternational.co.uk)

### 2.3.2.1 Weather Constraints

KPRO Façade rendering mortars should not be applied in periods of inclement weather. Excessive cold, heat, frost and rain can all have an effect on the performance of a rendering mortar at its time of application. I.S. EN 13914-1 and B.S. EN 13914-1 (section 7.9.1 – *Application of various coats*) provides the following information,

<b>Table 5</b>	
<b>Condition</b>	<b>Comment</b>
Cold	<ol style="list-style-type: none"> <li>1. Do not apply KPRO Façade renders to frozen or frost bound substrates.</li> <li>2. Do not apply KPRO Façade renders in temperatures below 5°C (this is at the face of the wall).</li> <li>3. Do not apply KPRO renders if frost or temperatures below 5°C are forecast during or soon after render application. The newly applied render coat must have adequate time to set and harden before temperatures fall below 5°C.</li> <li>4. If temperatures of 5°C cannot be maintained i.e. overnight, then work should be suspended until more favourable conditions resume.</li> </ol>
Hot	<ol style="list-style-type: none"> <li>1. Do not apply KPRO Façade renders in temperatures above 30°C.</li> <li>2. In extremes of hot weather avoid working on elevations subject to direct sunlight or walls, which will become sunny during the application. Apply material in the shade, preferably after direct sunlight has passed elevation/panel, and follow the shade around the building during the course of the day.</li> </ol>
Wet	<ol style="list-style-type: none"> <li>1. Do not during rainfall or if rainfall is anticipated during initial set unless full protection is provided.</li> <li>2. Don't render on saturated backgrounds as this can impair bond strength and cause unsightly lime bloom to occur.</li> <li>3. Don't allow rain to strike newly applied material, particularly if strong colours (KPRO Façade UNO) have been chosen for rendering.</li> <li>4. The suction of the background is critical and if there is doubt as to the amount of water in the substrate, sample panels should be carried out on trial areas to determine the effect on the render.</li> </ol>

#### Get in touch



**ROI** T: +353 (0)1 802 6300 E: technicaladmin@kilsaran.ie kilsaran.ie

**UK** T: +44 (0)161 872 8899 E: info@kilsaraninternational.co.uk kilsaraninternational.co.uk

### 2.3.2.2 Application of KPRO Façade GP Render

Prior to application of KPRO Façade GP Render ensure all necessary preparation of the background has been completed and that the wall is ready to receive the render coat.

KPRO Façade GP Render should be mixed with 4.5-5.0 litres of clean potable water (per 25kg bag) in a suitable mixer or continuous spray-render machine until a uniform material with a consistent workability is achieved. The material is a multi-coat render and applied in two separate coats.

KPRO Façade GP Render is suitable for both the undercoat and finish coat in a render system. Apply an approximate 10-12mm of material for the undercoat, incorporating the mesh cloth, and whilst the material is still fresh and workable, the surface is then levelled using a straight edge or serrated edge. The use of a serrated edge is beneficial in that it helps remove any air pockets formed during application. Once levelled use a plasterer's comb to comb the undercoat, providing a key for the follow on coats. Allow the undercoat to set, cure and harden before application of further coats. The freshly applied material must be protected from rain, mist and temperatures below +5°C, during the curing period.

Once the KPRO Façade undercoat has cured and dried (approximately 2 days) apply an approximate 8-10mm of material for the finish coat.

**Consecutive coats should be no thicker than previous coats.** Project design will dictate overall coat thickness required.

Whilst the material is still fresh and workable, the surface is then levelled using a straight edge or serrated edge. The use of a serrated edge is beneficial in that it helps remove any air pockets formed during application.

The applied material should then be ruled level and flattened with a spatula and allowed to gain its initial set/ pick up. The freshly applied material must be protected from rain, mist and temperatures below +5°C, during the curing period. Once the material has picked up undulations (high points) created during application can be removed with an I-section scraping tool. Apply the desired finish such as nap, sponge etc. Protect newly rendered surfaces from excessive drying caused by strong sunlight or prevailing winds. In sunny weather work should commence in the shade and follow the sun around the building during the course of the day. The freshly applied material must be protected from rain, mist and temperatures below +5°C, during the curing period



#### Get in touch



**ROI** T: +353 (0)1 802 6300 E: technicaladmin@kilsaran.ie kilsaran.ie

**UK** T: +44 (0)161 872 8899 E: info@kilsaraninternational.co.uk kilsaraninternational.co.uk



### 2.3.2.3 Application of KPRO Façade DuraRend

Prior to application of KPRO Façade DuraRend ensure all necessary preparation of the background has been completed and that the wall is ready to receive the render coat.



KPRO Façade DuraRend should be mixed with 4.75 - 5 litres of clean potable water (per 25kg bag) in a suitable mixer or continuous spray-render machine until a uniform material with a consistent workability is achieved. KPRO Façade DuraRend is applied in one coat consisting of two passes. The first pass should be applied at a thickness of 3-5mm, incorporating the mesh cloth, followed by a second pass (approximately 30 minutes later) to give a total monolithic coat thickness of 15-20mm.

Whilst the material is still fresh and workable, the surface is then levelled using a straight edge or serrated edge. The use of a serrated edge is beneficial in that it helps remove any air pockets formed during application.



The applied material should then be ruled level and flattened with a spatula and allowed to gain its initial set/ pick up.

The freshly applied material must be protected from rain, mist and temperatures below +5°C, during the curing period. Polythene sheeting is recommended for curing and should hang clear of the face of the wall ensuring not to form a tunnel through which the wind could increase the evaporation of water from the newly rendered surface. The sheeting must not be allowed to come into contact with the newly rendered surface as this could produce a patchy appearance.

Once the material has picked up undulations (high points) created during application can be removed with an I-section scraping tool. Apply the desired finish such as nap, sponge etc. Protect newly rendered surfaces from excessive drying caused by strong sunlight or prevailing winds. In sunny weather work should commence in the shade and follow the sun around the building during the course of the day.



The freshly applied material must be protected from rain, mist and temperatures below +5°C, during the curing period.

#### Get in touch



**ROI** T: +353 (0)1 802 6300 E: [technicaladmin@kilsaran.ie](mailto:technicaladmin@kilsaran.ie) [kilsaran.ie](http://kilsaran.ie)  
**UK** T: +44 (0)161 872 8899 E: [info@kilsaraninternational.co.uk](mailto:info@kilsaraninternational.co.uk) [kilsaraninternational.co.uk](http://kilsaraninternational.co.uk)

### 2.3.2.4 Application of KPRO Façade UNO

Prior to application of KPRO Façade UNO ensure all necessary preparation of the background has been completed and that the wall is ready to receive the render coat.

KPRO Façade UNO should be mixed with 5-6 litres of clean potable water (per 25kg bag) in a suitable mixer or continuous spray-render machine until a uniform material with a consistent workability is achieved. KPRO Façade UNO is applied in one coat, one pass.



Whilst the material is still fresh and workable, the surface is then levelled using a straight edge or serrated edge. The use of a serrated edge is beneficial in that it helps remove any air pockets formed during application.

The applied material should then be ruled level and flattened with a spatula to allow for finishing and to gain its initial set which is typically up to 16 hours (depending on substrate and drying conditions). Protect newly rendered surfaces from excessive drying caused by strong sunlight or prevailing winds. In sunny weather work should commence in the shade and follow the sun around the building during the course of the day.



The freshly applied material must be protected from rain, mist and temperatures below +5°C, during the curing period. Polythene sheeting is recommended for curing and should hang clear of the face of the wall ensuring not to form a tunnel through which the wind could increase the evaporation of water from the newly rendered surface. The sheeting must not be allowed to come into contact with the newly rendered surface as this could produce a patchy appearance.

When the product has cured sufficiently and gained an initial set the surface of the render is removed by using a toothed scrapper/nail float in a circular motion. 3-5mm of render should be removed in the scraping process, ensuring the thickness of the finished render is a minimum of 15mm and no greater than 20mm at any given point. During the finishing of scrape renders, undulations (high points) created during application can be removed with an I-section scraping tool.



#### Get in touch



**ROI** T: +353 (0)1 802 6300 E: technicaladmin@kilsaran.ie kilsaran.ie  
**UK** T: +44 (0)161 872 8899 E: info@kilsaraninternational.co.uk kilsaraninternational.co.uk

### 2.3.2.5 Application of KPRO Façade Dash

Prior to application of KPRO Façade Dash ensure all necessary preparation of the background has been completed and that the wall has received a suitable render undercoat coat of KPRO Façade GP Render.



KPRO Façade Dash should be mixed with 5-6 litres of clean potable water (per 25kg bag) in a suitable mixer or continuous spray-render machine until a uniform material with a consistent workability is achieved. The material is applied over a keyed undercoat at a thickness of 7-10 mm.



Whilst the material is still fresh and workable, the surface is then levelled using a straight edge or serrated edge. The use of a serrated edge is beneficial in that it helps remove any air pockets formed during application.

The applied material should then be ruled level and flattened with a spatula to allow for application of dashing stone. Protect newly rendered surfaces from excessive drying caused by strong sunlight or prevailing winds. In sunny weather work should commence in the shade and follow the sun around the building during the course of the day.



For single coat applications apply in one coat consisting of two passes. The first pass should be applied at a thickness of 3-5mm, incorporating the mesh cloth, followed by a second pass (approximately 30 minutes later) to give a total monolithic coat thickness of 20mm. Whilst the material is still fresh and workable, the surface is then levelled using a straight edge or serrated edge (as above).

Whilst the material is still fresh and workable on the wall throw the selected dashing stone onto the render surface using a dashing trowel. Ensure even coverage and tamp dashing stone into the surface with a wooden float if required.



The freshly applied material must be protected from rain, mist and temperatures below +5°C, during the curing period. Polythene sheeting is recommended for curing and should hang clear of the face of the wall ensuring not to form a tunnel through which the wind could increase the evaporation of water from the newly rendered surface. The sheeting must not be allowed to come into contact with the newly rendered surface as this could produce a patchy appearance.

#### Get in touch



**ROI** T: +353 (0)1 802 6300 E: technicaladmin@kilsaran.ie kilsaran.ie  
**UK** T: +44 (0)161 872 8899 E: info@kilsaraninternational.co.uk kilsaraninternational.co.uk

### 2.3.2.6 Application of KPRO Façade HLR

Prior to application of KPRO Façade HLR ensure all necessary preparation of the background has been completed and that the wall is ready to receive the render coat.

KPRO Façade HLR should be mixed with 5-6 litres of clean potable water (per 25kg bag) in a suitable mixer or continuous spray-render machine until a uniform material with a consistent workability is achieved. The material is a multi-coat render and applied in separate coats.

Dampen down the substrate with a fine mist immediately prior to application avoiding saturation. Apply a 10mm coat of material for the undercoat, incorporating the mesh cloth, and whilst the material is still fresh and workable, the surface is then levelled using a straight edge or serrated edge. The use of a serrated edge is beneficial in that it helps remove any air pockets formed during application. Once levelled use a plasterer's comb to comb the undercoat, providing a key for the follow on coats. Allow the undercoat to set, cure and harden before application of further coats.

Apply a second undercoat at a thickness of 8-10mm level and provide a key as described above.

Dampen down the substrate with a fine mist immediately prior to application avoiding saturation. Apply an 8mm coat of material for the finish coat and whilst the material is still fresh and workable, the surface is then levelled using a straight edge or serrated edge. The applied material should then be ruled level and flattened with a spatula and allowed to gain its initial set/ pick up.

The freshly applied material must be protected from rain, mist and temperatures below +5°C, during the curing period. Polythene sheeting is recommended for curing and should hang clear of the face of the wall ensuring not to form a tunnel through which the wind could increase the evaporation of water from the newly rendered surface. The sheeting must not be allowed to come into contact with the newly rendered surface as this could produce a patchy appearance.

Once the material has picked up undulations (high points) created during application can be removed with an I-section scraping tool. Apply the desired finish such as nap, sponge etc. Protect newly rendered surfaces from excessive drying caused by strong sunlight or prevailing winds. In sunny weather work should commence in the shade and follow the sun around the building during the course of the day.

The freshly applied material must be protected from rain, mist and temperatures below +5°C, during the curing period.



#### Get in touch



**ROI** T: +353 (0)1 802 6300 E: technicaladmin@kilsaran.ie kilsaran.ie  
**UK** T: +44 (0)161 872 8899 E: info@kilsaraninternational.co.uk kilsaraninternational.co.uk

### 3. Maintenance and repair

KPRO Façade rendering mortars are typically low maintenance materials. However, as with most building materials some maintenance and repair may be required over their lifetime to keep them looking and performing their best. The following guidance covers maintenance and repair based on our knowledge and the recommendations set out in I.S. EN 13914-1, B.S. EN 13914-1 and BRE GBG 24.

#### 3.1 Maintenance and repair – KPRO Façade GP Render/DuraRend

KPRO Façade GP Render is a natural coloured product designed to be given a painted or decorative finish. Regular checks should be carried out to ensure architectural details are shedding water clear of the building, are present and are functioning correctly. In addition, external plumbing fittings such as gutter and downpipes should be checked for condition and functioning.

##### 3.1.1 KPRO Façade GP Render/DuraRend cleaning

KPRO Façade GP Render should always be given a painted or given an appropriate decorative finish. The surfaces of these finishes may be cleaned as often as required ensuring to follow the manufacturer's guidelines for a given decorative product. Timing of cleaning cycles is solely dependent on local atmospheric conditions and exposure to pedestrian, cycle traffic etc. (ground floor locations). For surfaces affected with organic growth, such as algal, fungal etc. the affected areas should be brushed clean and treated with a suitable biological cleaning solution such as Kilsaran Ceresit CT 99.

##### 3.1.2 KPRO Façade GP Render/DuraRend repairs

As KPRO Façade GP Render is a natural grey coloured rendering mortar, designed to be given a decorative finish, it can be easily be patched or repaired without affecting the overall finished appearance of the façade. All newly repaired areas should be given the same finish as the surrounding render and in all instances the quality of the repair is highly dependent on the skill, experience and patience of the plastering contractor carrying out the work.

#### Get in touch



**ROI** T: +353 (0)1 802 6300 E: technicaladmin@kilsaran.ie kilsaran.ie

**UK** T: +44 (0)161 872 8899 E: info@kilsaraninternational.co.uk kilsaraninternational.co.uk

### 3.1.2.1 KPRO Façade GP Render/DuraRend repairs – damaged or debonded render

As a natural coloured rendering material, small knocks and scrapes can be repaired and given a decorative finish. If a repair is necessary or if an area of the rendered surface has become de-bonded, the material should be removed back to the substrate, and in the case of de-bonded areas removed back to the substrate until a stable, sound render edge is achieved.

Once all damaged and/or de-bonded render has been removed from the affected area, the edges of the existing render should be protected with masking tape, and a key coat of KPRO Façade Super Bond should be applied and allowed to cure. Following this, a coat of fresh KPRO Façade GP Render should be applied to the area, ensuring to leave the surface finish the same as that of the surrounding render.

### 3.1.2.2 KPRO Façade GP Render/DuraRend repairs – cracking

Precautions and guidelines for minimising the occurrence of cracks are outlined in this document and also I.S. EN 13914-1 and B.S. EN 13914-1, specifically Section 6.14.5 – *Methods of minimizing the occurrence of cracks*.

Before commencing any repairs to cracks, an investigation should first be undertaken to establish their possible cause and if future cracking may occur. Cracks following straight lines are not typical of render failure, but rather as a result of movement in the background and/or structure. In these instances, a survey of the affected area and its background should be conducted by a structural engineer.

A summarised list of crack locations and patterns associated with movement in the background/structure has been taken from I.S. EN 13914-1, B.S. EN 13914-1 and BRE document GBG 24. See table 6 below,

Table 6	
No.	Crack location/description
1.	Single cracks with a noticeably straight-lined course e.g. along masonry joints.
2.	Cracks with mostly vertical or horizontal orientation.
3.	Cracks that trace the course of masonry joints.
4.	Vertical cracks in the corner areas of masonry coinciding with wall thickness.
5.	Cracks connecting masonry openings with each other.
6.	Shear cracks.
7.	Diagonal cracks running from the corner area of openings.

#### Get in touch



**ROI** T: +353 (0)1 802 6300 E: technicaladmin@kilsaran.ie kilsaran.ie  
**UK** T: +44 (0)161 872 8899 E: info@kilsaraninternational.co.uk kilsaraninternational.co.uk

As per section 8.3.1 of I.S. EN 13914-1 and B.S. EN 13914-1, 'small inconspicuous cracks that remain dry and sound should be left alone'. For wider, visible cracks and damaged areas the following steps should be followed;

- 1.** Use a disc cutter to cut a straight line 50mm either side of the crack and remove render back to the substrate.
- 2.** Protect the other edges of the cut with masking tape and prime the inner edges of the channel with an SBR primer
- 3.** Whilst primer is still tacky apply a layer of GP Render/DuraRend to the area and insert a piece of mesh (>6mm aperture) cut to length and width. Then apply a further coat of GP Render/DuraRend (wet on wet)
- 4.** Allow the product to pick up and finish as per that of the surrounding area.
- 5.** Brush the dry product down to remove any dust and remove the making tape from the area.

#### Get in touch



**ROI** T: +353 (0)1 802 6300 E: technicaladmin@kilsaran.ie kilsaran.ie

**UK** T: +44 (0)161 872 8899 E: info@kilsaraninternational.co.uk kilsaraninternational.co.uk

### 3.1.2.3 KPRO Façade GP Render/DuraRend – Painting and decorative finishes

KPRO Façade GP Render and DuraRend are natural grey coloured products designed to be given a painted or decorative finish. Painting of KPRO Façade GP Render and DuraRend is possible using good quality masonry paints such as Kilsaran Ceresit CT 48 paint. Ensure the rendered surface is fully cured and dry prior to painting and always follow the instructions of the paint manufacturer.

### 3.1.2.4 KPRO Façade DuraRend Systems – Decorative finishes

KPRO Façade DuraRend provides an excellent substrate to receive resin (organic) render decorative finishes. Kilsaran DuraRend Classic is a system comprising of DuraRend render, a priming coat and a durable resin render finishing coat. Kilsaran resin renders, such as Ceresit CT 174 silicone-silicate render, CT 74 silicone render and are available in a wide range of colours, accommodating RAL numbers and NCS (Natural Colour Systems) colours. For more information on our resin render finishes please refer to our DuraRend brochure.

## 3.2 Maintenance and repair – KPRO Façade UNO

While KPRO Façade UNO is a through coloured and low maintenance render, regular checks should be carried out to ensure architectural details are shedding water clear of the building, are present and are functioning correctly. In addition, external plumbing fittings such as gutter and downpipes should be checked for condition and functioning.

### 3.2.1 KPRO Façade UNO cleaning

KPRO Façade UNO may be cleaned as often as required by means of hosing them down with water and giving them a light brushing, or occasionally by using a pressure washer and a mild masonry detergent diluted in the washing water. When using a pressure washer care should be taken not to hold the nozzle of the washer lance too close to the rendered surface. Ensure the spray nozzle is adjusted to allow a wide fan of water clean the surface from a distance, rather than concentrating a jet of water on any particular area. Timing of cleaning cycles is solely dependent on local atmospheric conditions and exposure to pedestrian, cycle traffic etc. (ground floor locations). For surfaces affected with organic growth, such as algal, fungal etc., the affected areas should be brushed clean and treated with a suitable biological cleaning solution such as Kilsaran Ceresit CT 99.

#### Get in touch



**ROI** T: +353 (0)1 802 6300 E: [technicaladmin@kilsaran.ie](mailto:technicaladmin@kilsaran.ie) [kilsaran.ie](http://kilsaran.ie)

**UK** T: +44 (0)161 872 8899 E: [info@kilsaraninternational.co.uk](mailto:info@kilsaraninternational.co.uk) [kilsaraninternational.co.uk](http://kilsaraninternational.co.uk)



### 3.2.2 KPRO Façade UNO repairs

KPRO Façade UNO is a through-coloured rendering mortars therefore once applied and finished any repairs undertaken are likely to be visible to some extent. As a result, Kilsaran always recommend that areas, needing repairs should have full panels removed and re-applied. In some cases, areas of the façade that have architectural or design features (such as ashlar cuts) can be used as an edge of a panel or section, making them suitable as a natural division between acceptable sections and those needing repair. All newly repaired areas will have a fresh 'new' appearance early in its life, but these areas should weather in over time. In all instances the quality of the repair is highly dependent on the skill, experience and patience of the plastering contractor carry out the work.

#### 3.2.2.1 KPRO Façade UNO repairs – damaged or debonded render

As KPRO Façade UNO is a through-coloured rendering mortar, small knocks and scrapes will not be as noticeable as with natural un-coloured traditional products that have a painted finish. If a repair is necessary or if an area of the rendered surface has become de-bonded, the material should be removed back to the substrate, and in the case of de-bonded areas removed back to the substrate until a stable, sound render edge is achieved.

Once all damaged and/or de-bonded render has been removed from the affected area, the edges of the existing render should be protected with masking tape, and a key coat of KPRO Façade Super Bond should be applied and allowed to cure. Following this, a coat of fresh KPRO Façade UNO should be applied to the area, ensuring to leave it 2-3mm proud of the existing surface. When the newly applied render has 'picked up' and an initial set has occurred, the surface should be given scraped finished, back flush with the surrounding area.

#### 3.2.2.2 KPRO Façade UNO repairs – cracking

Precautions and guidelines for minimising the occurrence of cracks are outlined in this document and also I.S. EN 13914-1 and B.S. EN 13914-1, specifically Section 6.14.5 – *Methods of minimizing the occurrence of cracks*.

Before commencing any repairs to cracks, an investigation should first be undertaken to establish their possible cause and if future cracking may occur. Cracks following straight lines are not typical of render failure, but rather as a result of movement in the background and/or structure. In these instances, a survey of the affected area and its background should be conducted by a structural engineer.

A summarised list of crack locations and patterns associated with movement in the background/structure has been taken from I.S. EN 13914-1, B.S. EN 13914-1 and BRE document GBG 24. See Table 6 in this document.

#### Get in touch



ROI T: +353 (0)1 802 6300 E: [technicaladmin@kilsaran.ie](mailto:technicaladmin@kilsaran.ie) [kilsaran.ie](http://kilsaran.ie)

UK T: +44 (0)161 872 8899 E: [info@kilsaraninternational.co.uk](mailto:info@kilsaraninternational.co.uk) [kilsaraninternational.co.uk](http://kilsaraninternational.co.uk)

As per section 8.3.1 of I.S. EN 13914-1 and B.S. EN 13914-1, 'small inconspicuous cracks that remain dry and sound should be left alone'. For wider, visible cracks the following steps should be followed;

- 1.** Protect render edges either die of the crack with masking tape.
- 2.** Use a cutting disc to cut a straight line through the crack, the width of the disc (no less than 2mm), back to the substrate or undercoat (if present)
- 3.** Vacuum or brush all loose material from the area and inject a ribbon of mendred fissure infill into the prepared area at a depth of 1-2mm.
- 4.** Whilst the mendred is still fresh, apply a ribbon of KPRO Facade UNO (matching colour) using a uitable pointing/caulking gun leaving it prud of the surrounding render by 2-3mm.
- 5.** Once the ribbon of KPRO Facade UNO had hardened remove the masking tape and scrape the surface of the repair in a circular motion using a micro scraper or corundum block to match the surface texture of the surrounding surface.

#### Get in touch



**ROI** T: +353 (0)1 802 6300 E: technicaladmin@kilsaran.ie kilsaran.ie

**UK** T: +44 (0)161 872 8899 E: info@kilsaraninternational.co.uk kilsaraninternational.co.uk

### 3.2.2.3 KPRO Façade UNO – Painting and decorative finishes

Painting of KPRO Façade UNO, whether to cover repaired areas or simply to change the colour of the façade, is possible using Kilsaran Ceresit CT 48 paint. Kilsaran Ceresit CT48 is a high performance silicone based paint ideal for use over KPRO Façade UNO. It may be necessary to prime the surface of the render before painting commences. If required prime the surface with Kilsaran Ceresit CT 17 and allow to fully dry (approximately 4 hours) before application of follow on coats. It also may be necessary to pre-treat the rendered surface with a suitable wash to remove dirt and organic material.

In this instance pre-treating the area with Kilsaran Ceresit CT99 is recommended. Once dry apply a coat of Kilsaran Ceresit CT 48 to the surface using a medium pile roller. For best results apply CT 48 in a criss-cross pattern to the rendered surface. Kilsaran Ceresit CT 48 is available in a wide range of colours, accommodating RAL numbers, NCS (Natural Colour Systems) colours and in colours complementing our One Coat Render colour range. Please note however that it is not possible to 100% colour match a mineral render colour with a synthetic product such as CT 48 silicone paint.

## 4. Drawing details

The following is a list of typical render details encountered on masonry substrates

### Get in touch



**ROI** T: +353 (0)1 802 6300 E: [technicaladmin@kilsaran.ie](mailto:technicaladmin@kilsaran.ie) [kilsaran.ie](http://kilsaran.ie)

**UK** T: +44 (0)161 872 8899 E: [info@kilsaraninternational.co.uk](mailto:info@kilsaraninternational.co.uk) [kilsaraninternational.co.uk](http://kilsaraninternational.co.uk)



DESIGN INFORMATION &  
BEST PRACTICE APPLICATION GUIDE

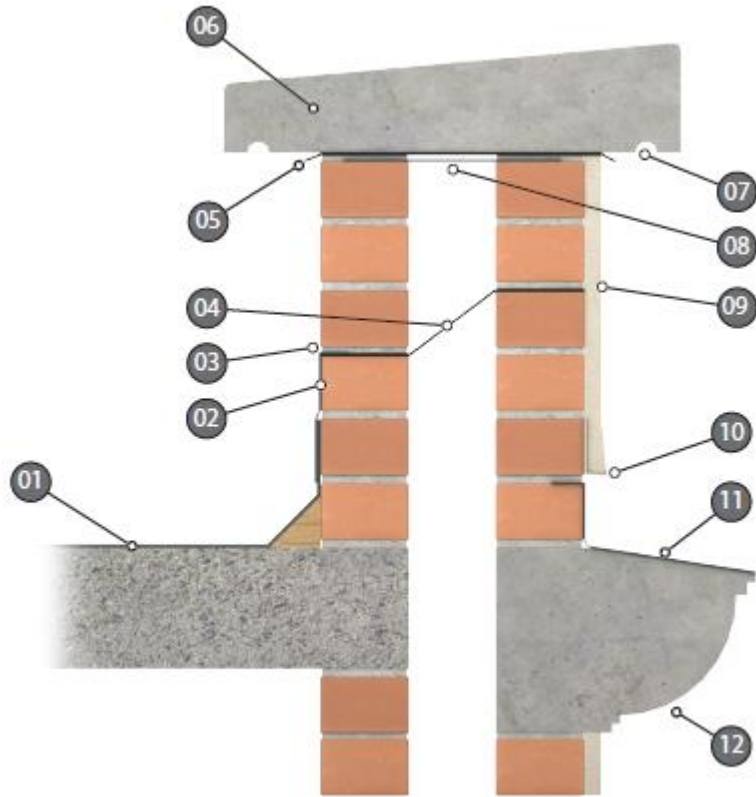

- 01. Roof Finish
- 02. Flashing
- 03. Weep Holes
- 04. Damp Proof Course
- 05. Damp Proof Course
- 06. Coping
- 07. Throat clear of Rendering (Min. 40mm)
- 08. Cavity Bridge
- 09. Rendering
- 10. Drip Bead / Bellcast Bead
- 11. Flashing
- 12. String Course

Kisaran  
**KPRO**  
 FAÇADE

**Title:**  
 DWG-001

**Title:**  
 Parapet and  
 Screen Walls

**Rev.** 01

**Revision Date:**  
 01/06/2020

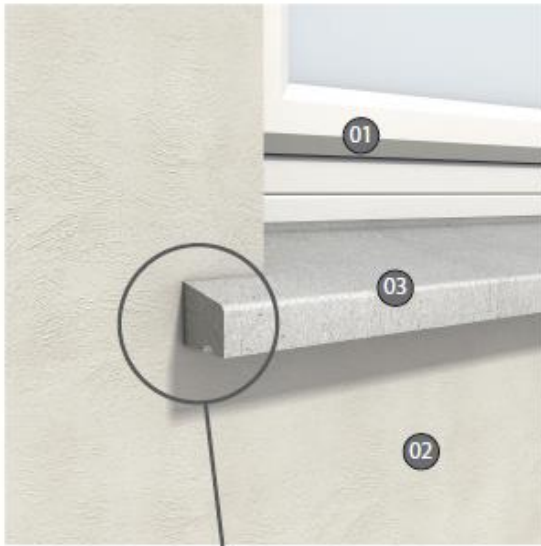

- 01. Window
- 02. Render
- 03. Sill

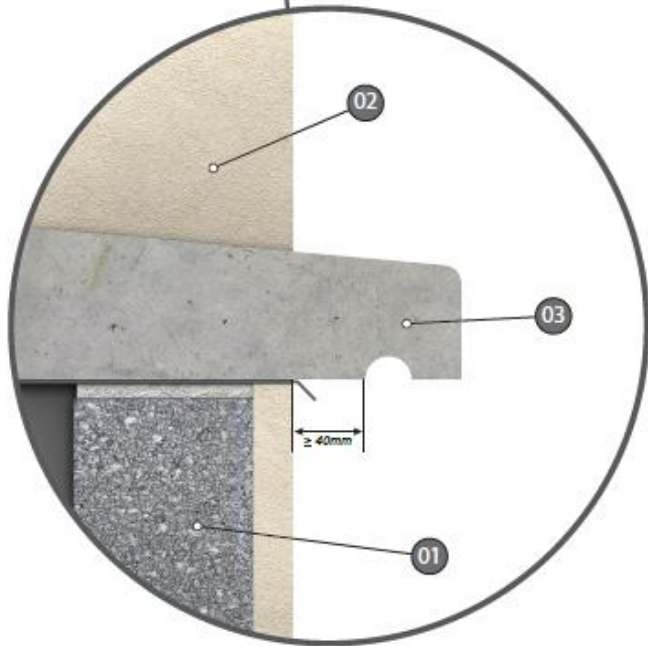

- 01. Wall
- 02. Render
- 03. Sill

<b>Drawing No.</b> DWG-002
<b>Title:</b> Sills - Concrete
<b>Rev.</b> 01
<b>Revision Date:</b> 01/06/2020

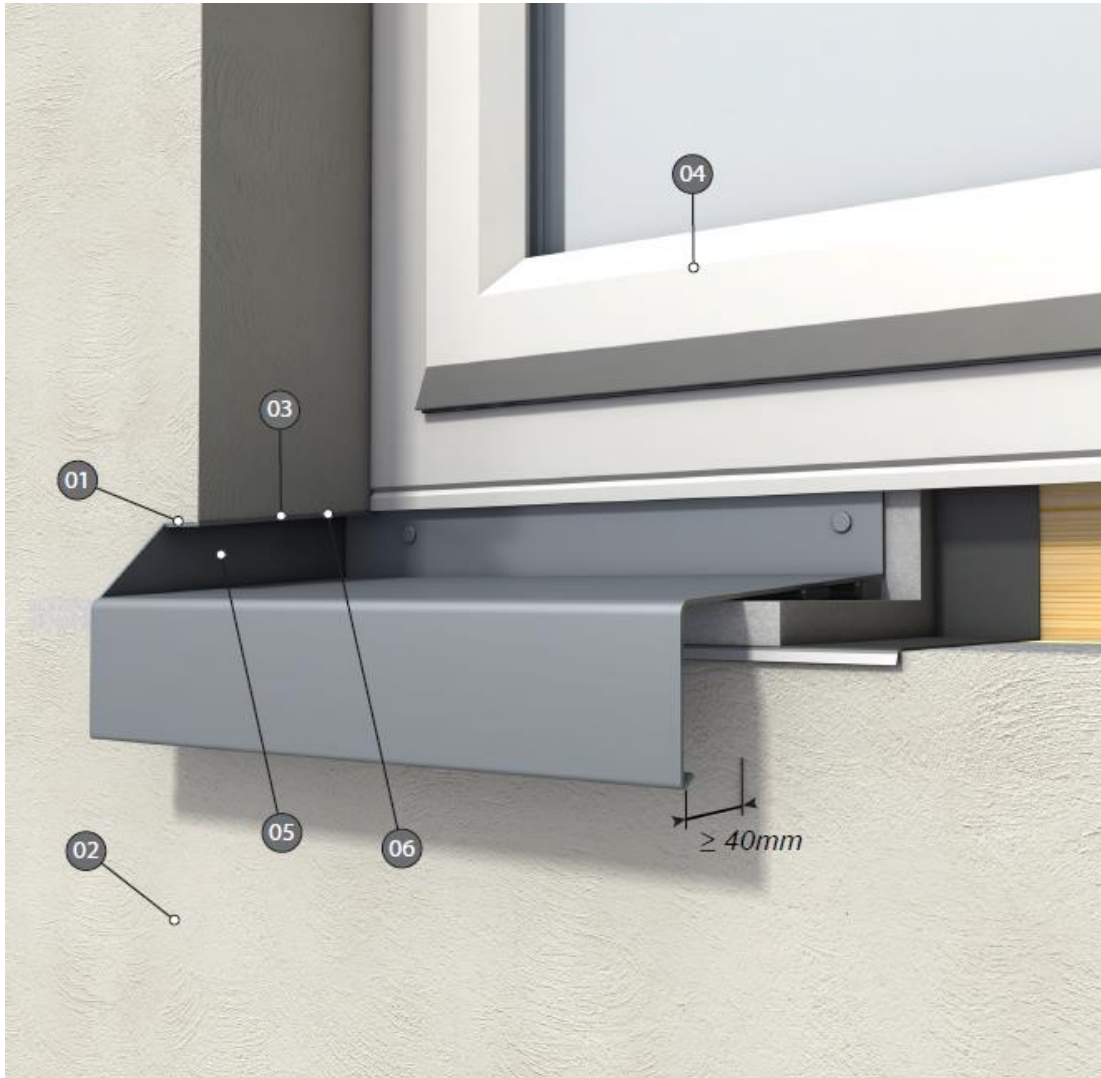

- 01. Horizontal base of render or sloping as the sill
- 02. Rendered Wall
- 03. Sill Lip
- 04. Window
- 05. Upstand
- 06. Face of Render forward of lip

KİLSARAN  
**KPRO**  
FAÇADE

**Drawing No.**  
DWG-003

**Title:**  
Sills - Metal

**Rev. 01**

**Revision Date:**  
01/06/2020

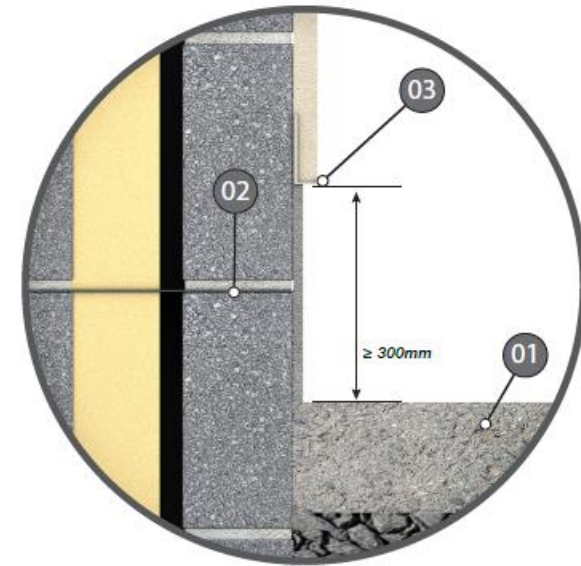
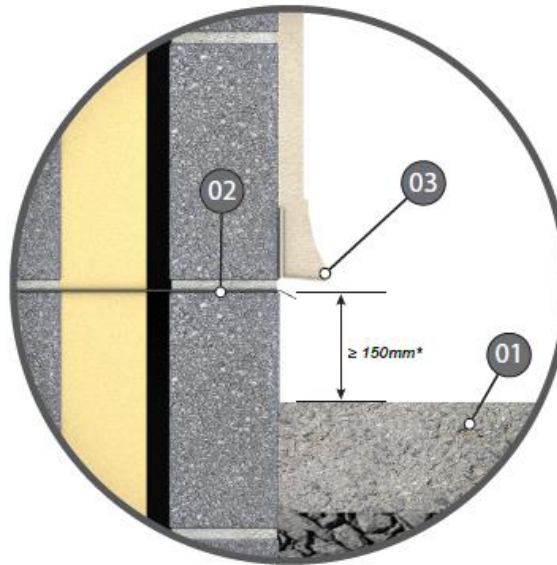
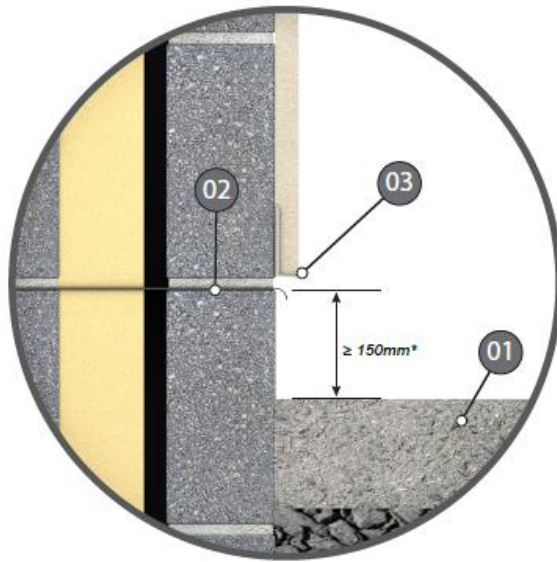

- 01. Ground Level
- 02. Damp Proof Course
- 03. Socle or Drip Bead

*\* A higher minimum distance may be necessary due to local climatic conditions*

Kisaran  
**KPRO**  
FAÇADE

**Drawing No.**  
DWG-004

**Title:**  
Rendering at  
base of Walls

**Rev.** 01

**Revision Date:**  
01/06/2020



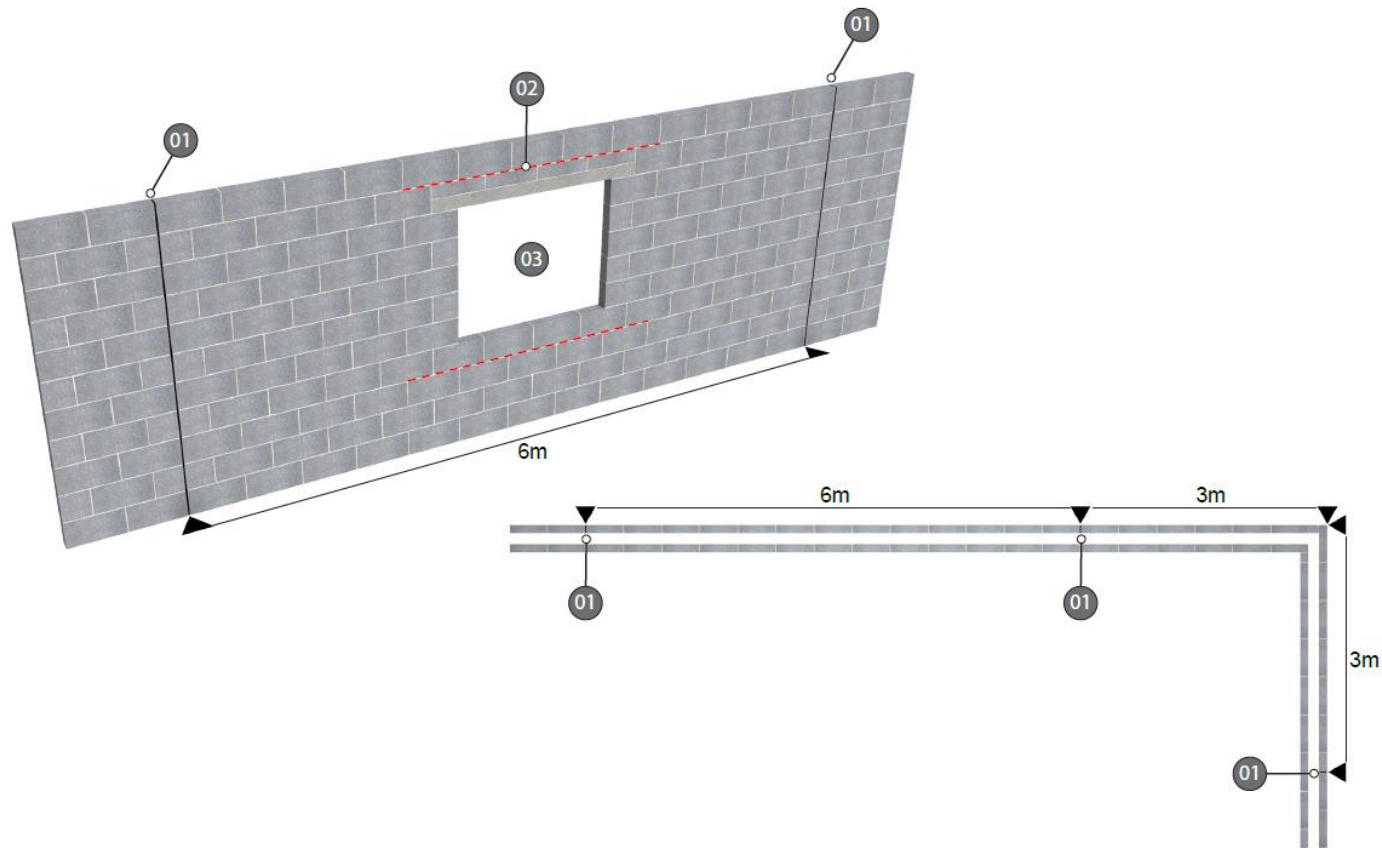

- 01. Movement Joint
- 02. Bed Joint Reinforcement
- 03. Window Opening

<b>Drawing No.</b> DWG-005
<b>Title:</b> Spacing of Movement Joints
<b>Rev.</b> 01
<b>Revision Date:</b> 01/06/2020

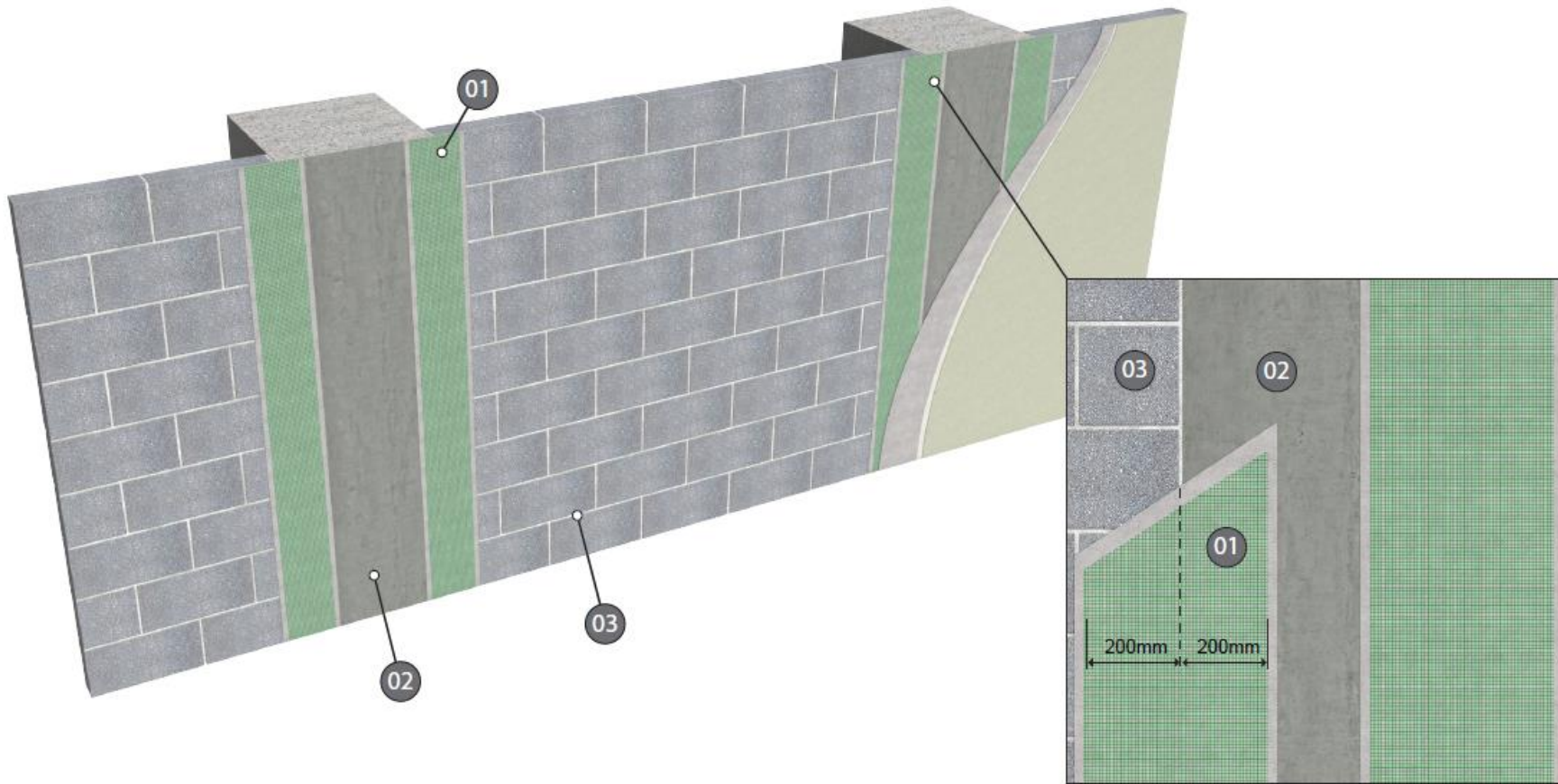

01. Alkali Resistant fibreglass mesh cloth with a resistance of tearing not less than 1.5kN/5cm

02. Concrete Substrate

03. Masonry Block Substrate

KİLSARAN  
**KPRO**  
FAÇADE

**Drawing No.**  
DWG-006

**Title:**  
Rendering  
across dissimilar  
backgrounds

**Rev.** 01

**Revision Date:**  
01/06/2020

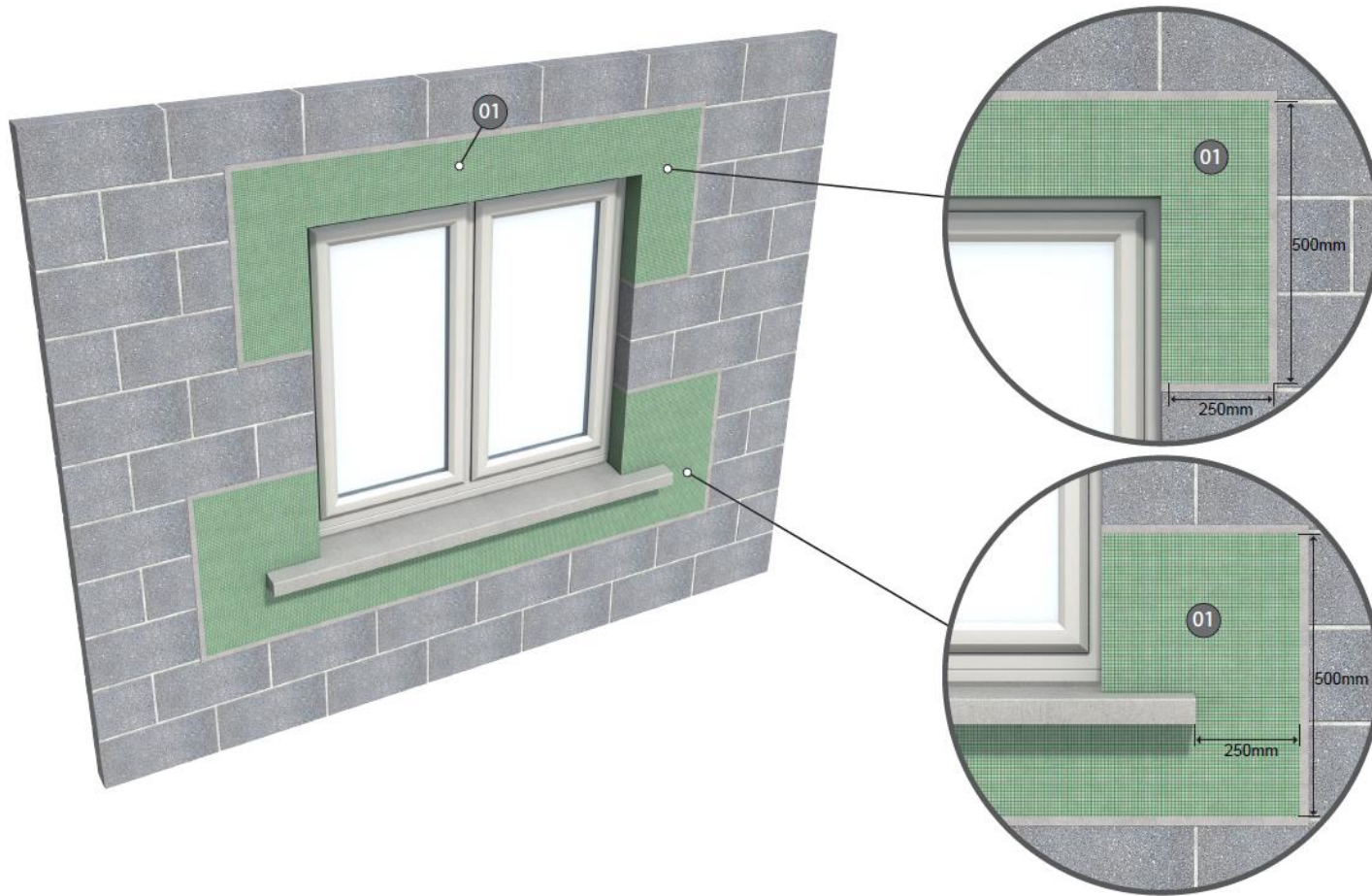

01. Alkali Resistant fibreglass mesh cloth with a resistance of tearing not less than 1.5kN/5cm

KİSARAN  
**KPRO**  
FAÇADE

**Drawing No.**  
DWG-007

**Title:**  
Mesh  
Reinforcement  
around openings

**Rev.** 01

**Revision Date:**  
01/06/2020

Sketches/Notes